

NuLAB PHENOLIC CASEWORK

BASE CABINETS - STANDING HEIGHT 35" HIGH X 22" DEEP

LAST TWO DIGITS OF MODEL # INDICATES CABINET WIDTH

ALL CUPBOARDS TO HAVE (1) FULL DEPTH ADJUSTABLE SHELF

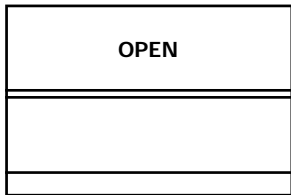

THB1 -30 THB1 -36
THB1 -42 THB1 -48

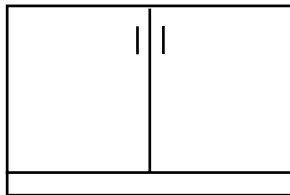

THB2 -30 THB2 -36
THB2 -42 THB2 -48

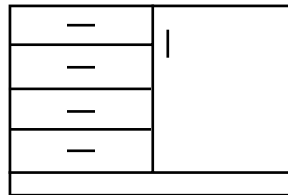

THB3 -30 THB3 -36
THB3 -42 THB3 -48

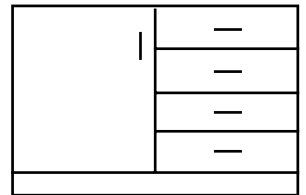

THB4 -30 THB4 -36
THB4 -42 THB4 -48

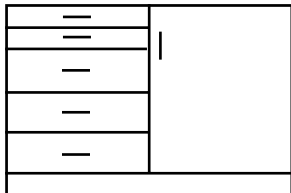

THB5 -30 THB5 -36
THB5 -42 THB5 -48

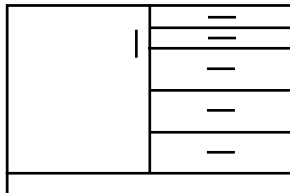

THB6 -30 THB6 -36
THB6 -42 THB6 -48

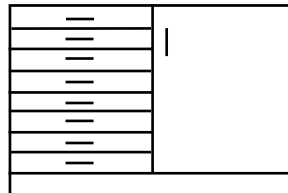

THB7 -30 THB7 -36
THB7 -42 THB7 -48

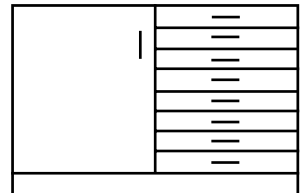

THB8 -30 THB8 -36
THB8 -42 THB8 -48

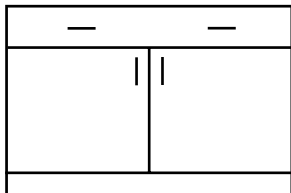

THB9 -30 THB9 -36
THB9 -42 THB9 -48

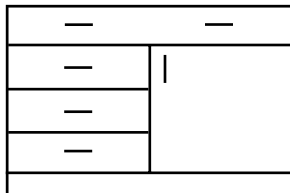

THB10 -30 THB10 -36
THB10 -42 THB10 -48

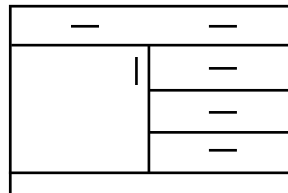

THB11 -30 THB11 -36
THB11 -42 THB11 -48

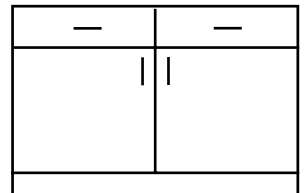

THB12 -30 THB12 -36
THB12 -42 THB12 -48

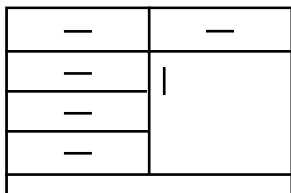

THB13 -30 THB13 -36
THB13 -42 THB13 -48

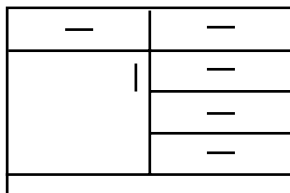

THB14 -30 THB14 -36
THB14 -42 THB14 -48

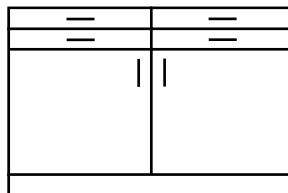

THB15 -30 THB15 -36
THB15 -42 THB15 -48

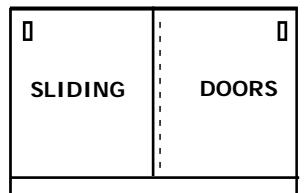

THB16 -30 THB16 -36
THB16 -42 THB16 -48

NuLAB FURNITURE CORPORATION

11 FEDERAL ROAD Monroe Twp., NJ 08831 (732) 792-0050 FAX 792-0721

NuLAB PHENOLIC CASEWORK

BASE CABINETS - STANDING HEIGHT 35" HIGH X 22" DEEP

LAST TWO DIGITS OF MODEL # INDICATES CABINET WIDTH

ALL CUPBOARDS TO HAVE (1) FULL DEPTH ADJUSTABLE SHELF

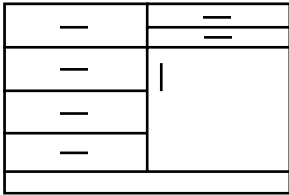

THB17 -30 THB17 -36
THB17 -42 THB17 -48

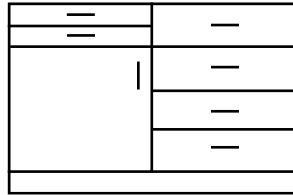

THB18 -30 THB18 -36
THB18 -42 THB18 -48

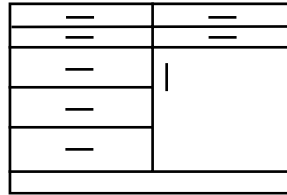

THB19 -30 THB19 -36
THB19 -42 THB19 -48

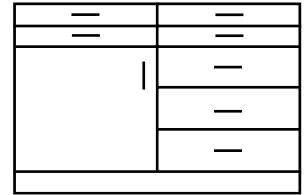

THB20 -30 THB20 -36
THB20 -42 THB20 -48

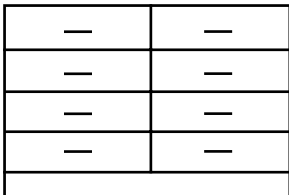

THB21 -30 THB21 -36
THB21 -42 THB21 -48

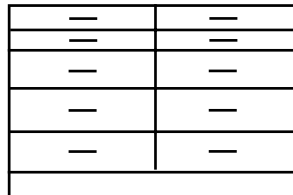

THB22 -30 THB22 -36
THB22 -42 THB22 -48

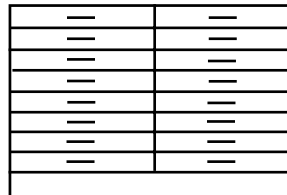

THB23 -30 THB23 -36
THB23 -42 THB23 -48

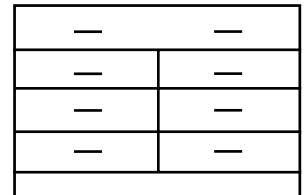

THB24 -30 THB24 -36
THB24 -42 THB24 -48

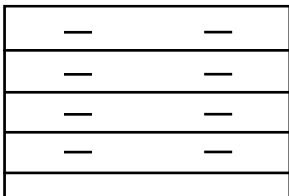

THB25 -30 THB25 -36
THB25 -42 THB25 -48

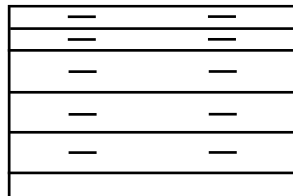

THB26 -30 THB26 -36
THB26 -42 THB26 -48

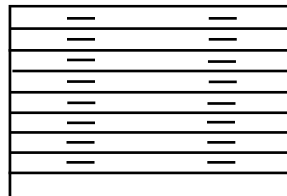

THB27 -30 THB27 -36
THB27 -42 THB27 -48

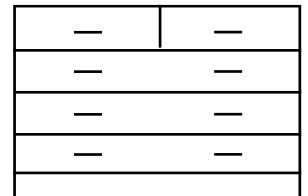

THB28 -30 THB28 -36
THB28 -42 THB28 -48

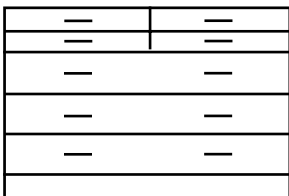

THB29 -30 THB29 -36
THB29 -42 THB29 -48

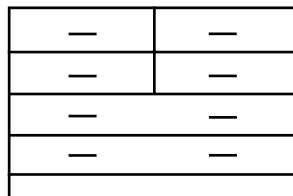

THB30 -30 THB30 -36
THB30 -42 THB30 -48

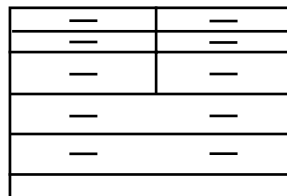

THB31 -30 THB31 -36
THB31 -42 THB31 -48

NuLAB FURNITURE CORPORATION

11 FEDERAL ROAD Monroe Twp., NJ 08831 (732) 792-0050 FAX 792-0721

NuLAB PHENOLIC CASEWORK

BASE CABINETS - STANDING HEIGHT 35" HIGH X 22" DEEP

LAST TWO DIGITS OF MODEL # INDICATES CABINET WIDTH

ALL CUPBOARDS TO HAVE (1) FULL DEPTH ADJUSTABLE SHELF

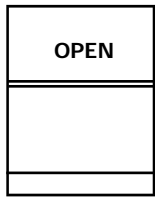

**THB32 -18
THB32 -24**

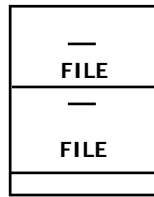

THB33 -18

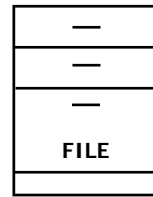

THB34 -18

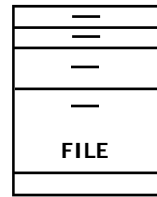

THB35 -18

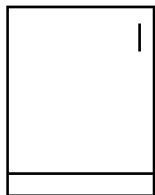

**THB36 -18
THB36 -24**

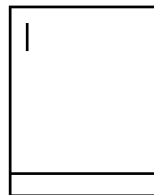

**THB37 -18
THB37 -24**

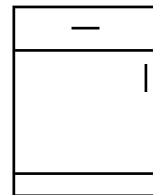

**THB38 -18
THB38 -24**

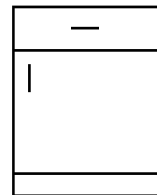

**THB39 -18
THB39 -24**

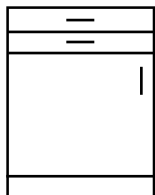

**THB40 -18
THB40 -24**

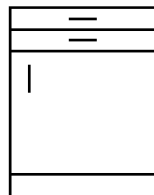

**THB41 -18
THB41 -24**

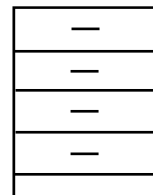

**THB42 -18
THB42 -24**

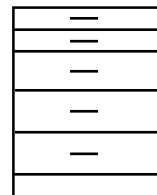

**THB43 -18
THB43 -24**

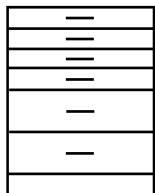

**THB44 -18
THB44 -24**

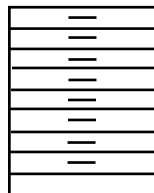

**THB45 -18
THB45 -24**

NuLAB FURNITURE CORPORATION

11 FEDERAL ROAD Monroe Twp., NJ 08831 (732) 792-0050 FAX 792-0721

NuLAB PHENOLIC CASEWORK

BASE CABINETS - SITTING HEIGHT 29" HIGH X 22" DEEP

LAST TWO DIGITS OF MODEL # INDICATES CABINET WIDTH

ALL CUPBOARDS TO HAVE (1) FULL DEPTH ADJUSTABLE SHELF

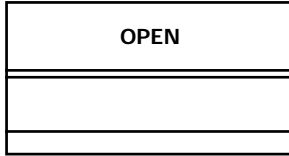

TLB1 -30 TLB1 -36
TLB1 -42 TLB1 -48

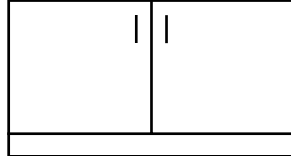

TLB2 -30 TLB2 -36
TLB2 -42 TLB2 -48

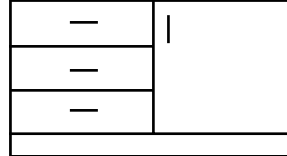

TLB3 -30 TLB3 -36
TLB3 -42 TLB3 -48

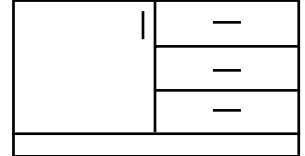

TLB4 -30 TLB4 -36
TLB4 -42 TLB4 -48

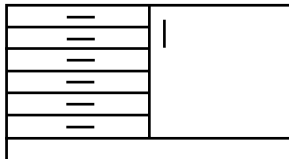

TLB5 -30 TLB5 -36
TLB5 -42 TLB5 -48

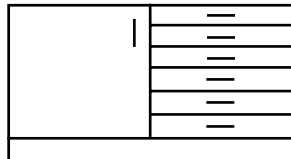

TLB6 -30 TLB6 -36
TLB6 -42 TLB6 -48

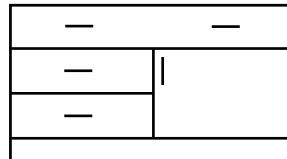

TLB7 -30 TLB7 -36
TLB7 -42 TLB7 -48

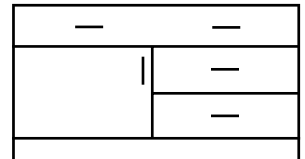

TLB8 -30 TLB8 -36
TLB8 -42 TLB8 -48

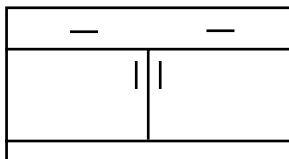

TLB9 -30 TLB9 -36
TLB9 -42 TLB9 -48

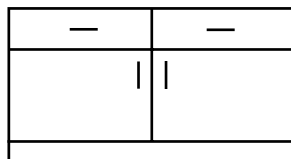

TLB10 -30 TLB10 -36
TLB10 -42 TLB10 -48

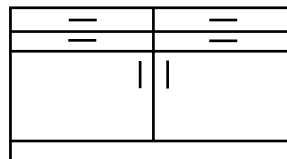

TLB11 -30 TLB11 -36
TLB11 -42 TLB11 -48

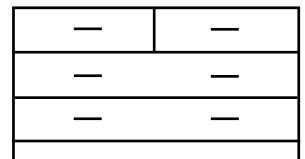

TLB12 -30 TLB12 -36
TLB12 -42 TLB12 -48

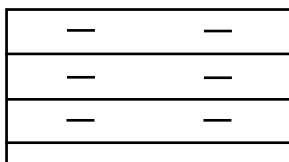

TLB13 -30 TLB13 -36
TLB13 -42 TLB13 -48

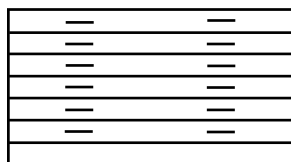

TLB14 -30 TLB14 -36
TLB14 -42 TLB14 -48

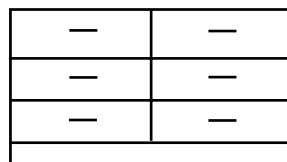

TLB15 -30 TLB15 -36
TLB15 -42 TLB15 -48

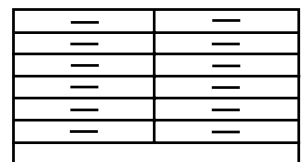

TLB16 -30 TLB16 -36
TLB16 -42 TLB16 -48

NuLAB FURNITURE CORPORATION

11 FEDERAL ROAD Monroe Twp., NJ 08831 (732) 792-0050 FAX 792-0721

NuLAB PHENOLIC CASEWORK

BASE CABINETS - SITTING HEIGHT 29" HIGH X 22" DEEP

LAST TWO DIGITS OF MODEL # INDICATES CABINET WIDTH

ALL CUPBOARDS TO HAVE (1) FULL DEPTH ADJUSTABLE SHELF



TLB17 -18
TLB17 -24

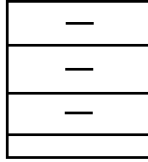

TLB18 -18
TLB18 -24

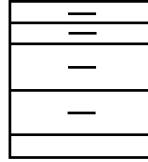

TLB19 -18
TLB19 -24

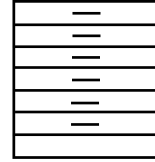

TLB20 -18
TLB20 -24

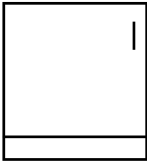

TLB21 -18
TLB21 -24

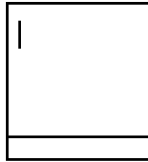

TLB22 -18
TLB22 -24

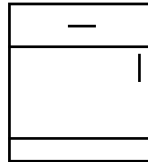

TLB23 -18
TLB23 -24

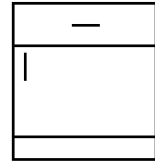

TLB24 -18
TLB24 -24

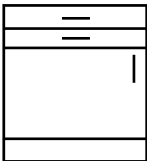

TLB25 -18
TLB25 -24



TLB26 -18
TLB26 -24

Revised 8-16-05

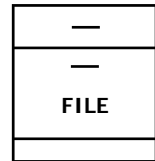

TLB27 -18

NuLAB FURNITURE CORPORATION

11 FEDERAL ROAD Monroe Twp., NJ 08831 (732) 792-0050 FAX 792-0721

NuLAB PHENOLIC CASEWORK

SINK CABINETS - 22" DEEP & 29" DEEP WHERE NOTED*

LAST TWO DIGITS OF MODEL # INDICATES CABINET WIDTH

ALL SINK CABINETS TO HAVE LOWER REAR RAIL & 8" HIGH BACK MEASURED FROM THE INSIDE BOTTOM

SITTING HEIGHT - 29" HIGH

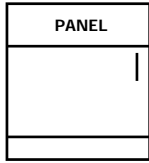

TSLB1 -18
TSLB1 -24

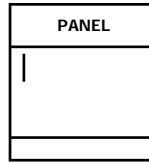

TSLB2 -18
TSLB2 -24

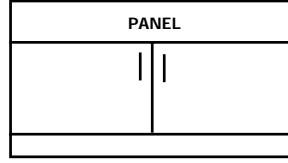

TSLB3 -30 TSLB3 -36
TSLB3 -42 TSLB3 -48

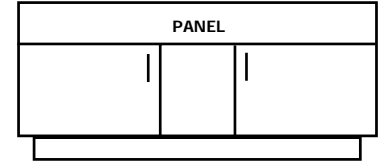

TSLB4 -52* TSLB4 -58*
ABOVE UNITS AVAILABLE
IN 20 1/8" & 29" DEPTH*

STANDING HEIGHT - 35" HIGH

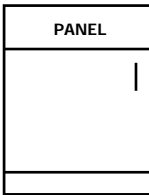

TSHB1 -18
TSHB1 -24

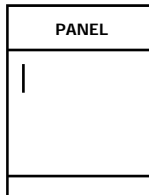

TSHB2 -18
TSHB2 -24

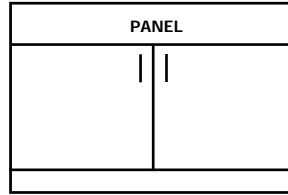

TSHB3 -30 TSHB3 -36
TSHB3 -42 TSHB3 -48

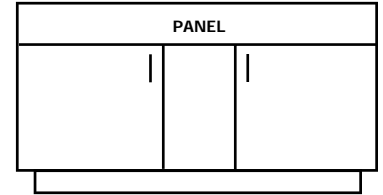

TSHB4 -52* TSHB4 -58*
ABOVE UNITS AVAILABLE
IN 20 1/8" & 29" DEPTH*

FUMEHOOD BASES

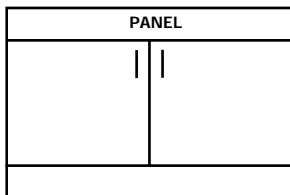

TFHB1 -30 TFHB1 -36
TFHB1 -42 TFHB1 -48
35" HIGH
29" HIGH UPON REQUEST

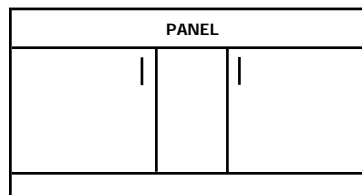

TFHB3 -60
35" HIGH
29" HIGH UPON REQUEST

CORNER ANGLE BASES

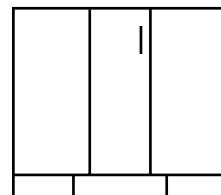

TCHB -1
35" HIGH

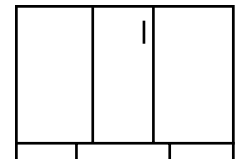

TCLB-1
29" HIGH

CORNER UNITS ABOVE AVAILABLE WITH
ROTATING LAZY SUSAN SHELF*
FIXED TECH RESIN SHELF AVAILABLE*

NuLAB FURNITURE CORPORATION

11 FEDERAL ROAD Monroe Twp., NJ 08831 (732) 792-0050 FAX 792-0721

NuLAB PHENOLIC CASEWORK

ADA CABINETS - 33" HIGH X 22" DEEP

LAST TWO DIGITS OF MODEL # INDICATES CABINET WIDTH

ALL CUPBOARDS TO HAVE (1) FULL DEPTH ADJUSTABLE SHELF



TA1 -18
TA1 -24

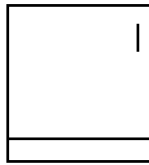

TA2 -18
TA2 -24

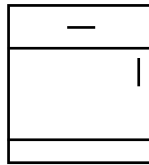

TA3 -18
TA3 -24

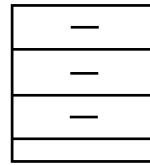

TA4 -18
TA4 -24

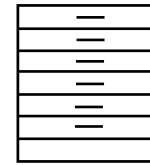

TA5 -18
TA5 -24

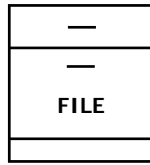

TA6 -18

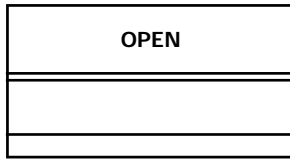

TA7 -30 TA7 -36
TA7 -42 TA7 -48

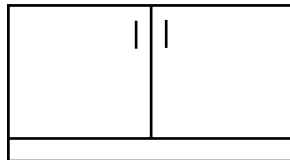

TA8 -30 TA8 -36
TA8 -42 TA8 -48

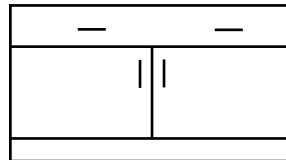

TA9 -30 TA9 -36
TA9 -42 TA9 -48

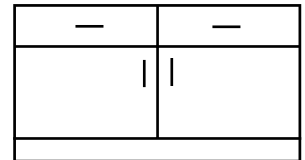

TA10 -30 TA10 -36
TA10 -42 TA10 -48

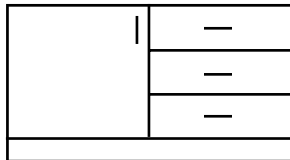

TA11 -30 TA11 -36
TA11 -42 TA11 -48

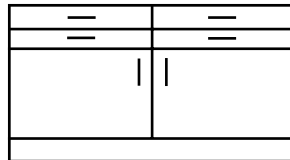

TA12 -30 TA12 -36
TA12 -42 TA12 -48

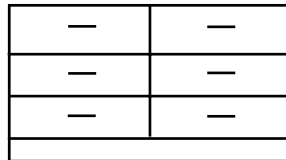

TA13 -30 TA13 -36
TA13 -42 TA13 -48

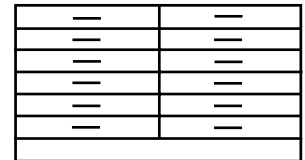

TA14 -30 TA14 -36
TA14 -42 TA14 -48

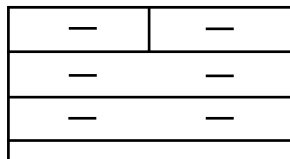

TA15 -30 TA15 -36
TA15 -42 TA15 -48

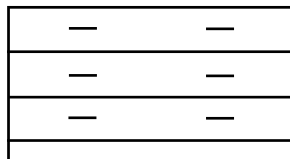

TA16 -30 TA16 -36
TA16 -42 TA16 -48

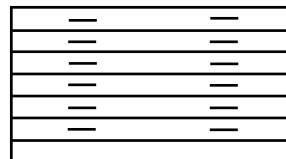

TA17 -30 TA17 -36
TA17 -42 TA17 -48

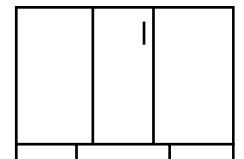

TAC-18
CORNER

ADA SINK CABINETS - 22" DEEP

ALL SINK CABINETS TO HAVE LOWER REAR RAIL & 8" HIGH BACK MEASURED FROM THE INSIDE BOTTOM

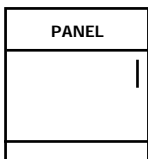

TA19 -18
TA19 -24

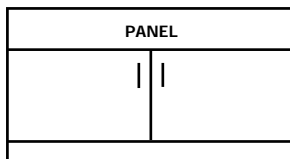

TA20 -30 TA20 -36
TA20 -42 TA20 -48

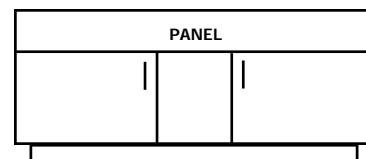

TA21 -52 TA21 -58

NuLAB FURNITURE CORPORATION

11 FEDERAL ROAD Monroe Twp., NJ 08831 (732) 792-0050 FAX 792-0721

NuLAB PHENOLIC CASEWORK

APRONS & DRAWER SECTIONS - 5" HIGH X 22" DEEP

LAST TWO DIGITS OF MODEL # INDICATES WIDTH



APRON FRONTS

AF-18 AF-42
 AF-24 AF-48
 AF-30 AF-54
 AF-36 AF-60



FULL BOX APRON

AP-18 AP-42
 AP-24 AP-48
 AP-30 AP-54
 AP-36 AP-60

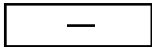

SINGLE DRAWER SECTION

D1-24

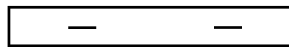

SINGLE DRAWER SECTION

D1-30 D1-36
 D1-42 D1-48

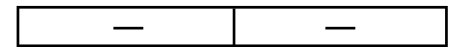

DOUBLE DRAWER SECTION

D2-36 D2-42
 D2-48 D2-54

REMOVABLE KNEE SPACE PANELS

FINISHED END PANELS

STANDING HEIGHT

HKSP-18
 HKSP-24
 HKSP-30
 HKSP-36
 HKSP-42
 HKSP-48
 HKSP-54

SITTING HEIGHT

LKSP-18
 LKSP-24
 LKSP-30
 LKSP-36
 LKSP-42
 LKSP-48
 LKSP-54

STANDING HEIGHT

HEP-20 22" DEEP
 HEP-29 29" DEEP

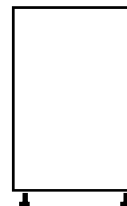

SITTING HEIGHT

LEP-20 22" DEEP
 LEP-29 29" DEEP

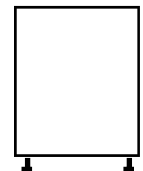

NuLAB FURNITURE CORPORATION

11 FEDERAL ROAD Monroe Twp., NJ 08831 (732) 792-0050 FAX 792-0721

NuLAB PHENOLIC CASEWORK

WALL CABINETS - 12" & 16" DEEP

LAST TWO DIGITS OF MODEL # INDICATES CABINET WIDTH
WHEN SPECIFYING 16" DEEP ADD SUFFIX 16 i.e. TW1-18-16

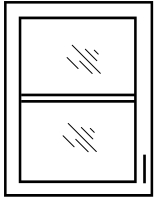

HINGED GLASS

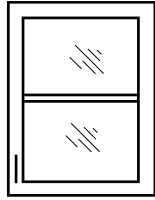

HINGED GLASS

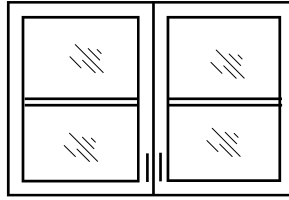

HINGED GLASS

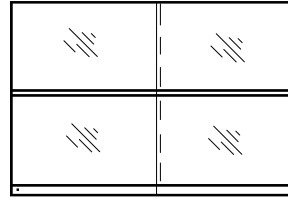

**FRAMELESS
SLIDING GLASS**

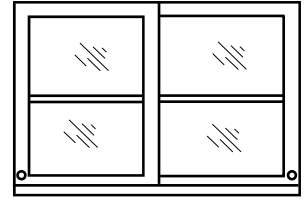

**FRAMED
SLIDING GLASS**

WALL HUNG CABINETS: 30" HIGH WITH (1) SHELF

TW1 -18
TW1 -24

TW2 -18
TW2 -24

TW3 -30 TW3 -36
TW3 -42 TW3 -48

TW4 -30 TW4 -36
TW4 -42 TW4 -48

TW5 -30 TW5 -36
TW5 -42 TW5 -48

WALL HUNG CABINETS: 36" HIGH WITH (2) SHELVES

TW6 -18
TW6 -24

TW7 -18
TW7 -24

TW8 -30 TW8 -36
TW8 -42 TW8 -48

TW9 -30 TW9 -36
TW9 -42 TW9 -48

TW10 -30 TW10 -36
TW10 -42 TW10 -48

WALL HUNG CABINETS: 48" HIGH WITH (3) SHELVES

TW11 -18
TW11 -24

TW12 -18
TW12 -24

TW13 -30 TW13 -36
TW13 -42 TW13 -48

TW14 -30 TW14 -36
TW14 -42 TW14 -48

TW15 -30 TW15 -36
TW15 -42 TW15 -48

NuLAB FURNITURE CORPORATION

11 FEDERAL ROAD Monroe Twp., NJ 08831 (732) 792-0050 FAX 792-0721

NuLAB PHENOLIC CASEWORK

WALL CABINETS - 12" & 16" DEEP

LAST TWO DIGITS OF MODEL # INDICATES CABINET WIDTH
WHEN SPECIFYING 16" DEEP ADD SUFFIX 16 i.e. TW1-18-16

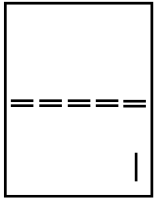

HINGED SOLID

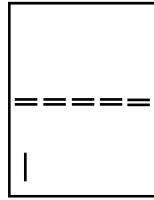

HINGED SOLID

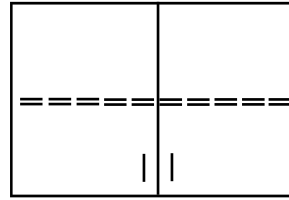

HINGED SOLID

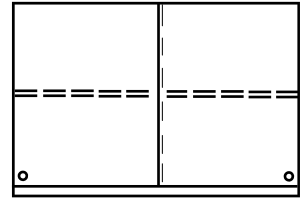

SLIDING SOLID

WALL HUNG CABINETS: 30" HIGH WITH (1) SHELF

TW16 -18
TW16 -24

TW17 -18
TW17 -24

TW18 -30 TW18 -36
TW18 -42 TW18 -48

TW19 -30 TW19 -36
TW19 -42 TW19 -48

WALL HUNG CABINETS: 36" HIGH WITH (2) SHELVES

TW20 -18
TW20 -24

TW21 -18
TW21 -24

TW22 -30 TW22 -36
TW22 -42 TW22 -48

TW23 -30 TW23 -36
TW23 -42 TW23 -48

WALL HUNG CABINETS: 48" HIGH WITH (3) SHELVES

TW24 -18
TW24 -24

TW25 -18
TW25 -24

TW26 -30 TW26 -36
TW26 -42 TW26 -48

TW27 -30 TW27 -36
TW27 -42 TW27 -48

NuLAB FURNITURE CORPORATION

11 FEDERAL ROAD Monroe Twp., NJ 08831 (732) 792-0050 FAX 792-0721

NuLAB PHENOLIC CASEWORK

WALL CABINETS - 12" & 16" DEEP

LAST TWO DIGITS OF MODEL # INDICATES CABINET WIDTH
WHEN SPECIFYING 16" DEEP ADD SUFFIX 16 i.e. TW1-18-16

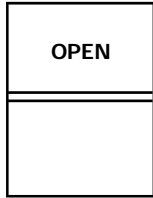

OPEN FRONT

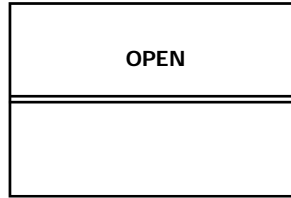

OPEN FRONT

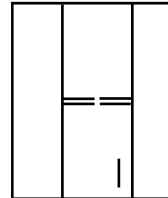

CORNER
HINGED SOLID

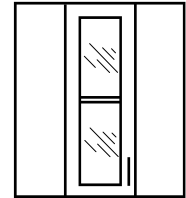

CORNER
HINGED GLASS

WALL HUNG CABINETS: 30" HIGH WITH (1) SHELF

TW28 -18
TW28 -24

TW29 -30 TW29 -36
TW29 -42 TW29 -48

TCW -30

TCW -31

WALL HUNG CABINETS: 36" HIGH WITH (2) SHELVES

TW32 -18
TW32 -24

TW33 -30 TW33 -36
TW33 -42 TW33 -48

TCW -34

TCW -35

WALL HUNG CABINETS: 48" HIGH WITH (3) SHELVES

TW36 -18
TW36 -24

TW37 -30 TW37 -36
TW37 -42 TW37 -48

TCW -38

TCW -39

NuLAB PHENOLIC CASEWORK

TALL STORAGE CABINETS - 16" & 22" DEEP
LAST TWO DIGITS OF MODEL # INDICATES CABINET WIDTH
WHEN SPECIFYING 22" DEEP ADD SUFFIX 22 i.e. TT1-18-22

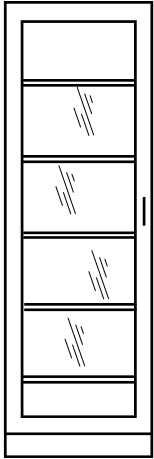

HINGED GLASS

TS1 -18
 TS1 -24

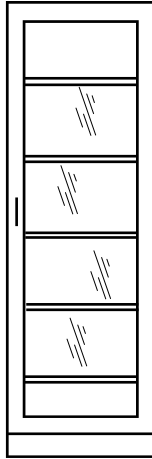

HINGED GLASS

TS2 -18
 TS2 -24

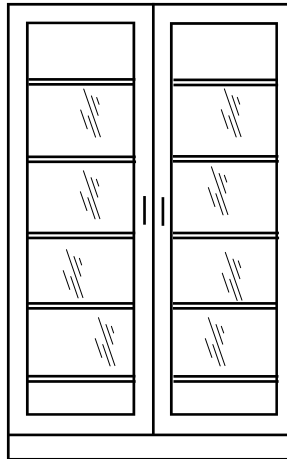

HINGED GLASS

TS3 -30 TS3 -36
 TS3 -42 TS3 -48

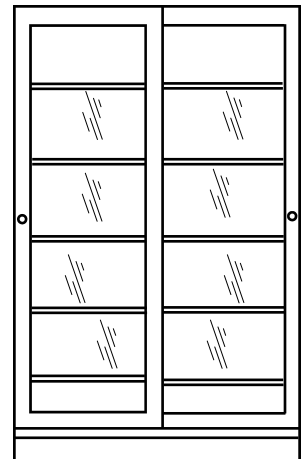

**FRAMED
 SLIDING GLASS**

TS4 -30 TS4 -36
 TS4 -42 TS4 -48

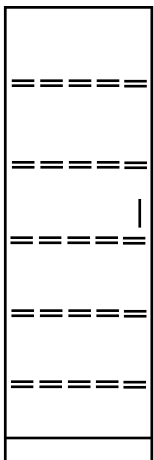

HINGED SOLID

TS5 -18
 TS5 -24

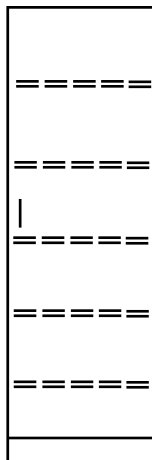

HINGED SOLID

TS6 -18
 TS6 -24

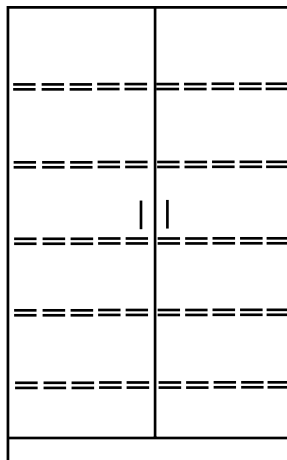

HINGED SOLID

TS7 -30 TS7 -36
 TS7 -42 TS7 -48

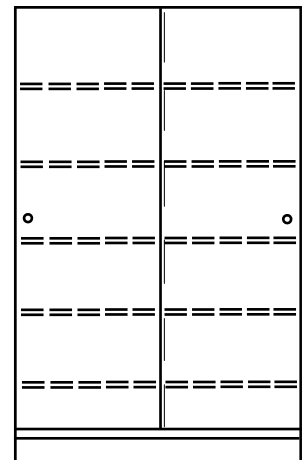

SLIDING SOLID

TS8 -30 TS8 -36
 TS8 -42 TS8 -48

NuLAB FURNITURE CORPORATION

11 FEDERAL ROAD Monroe Twp., NJ 08831 (732) 792-0050 FAX 792-0721

NuLAB PHENOLIC CASEWORK

TALL STORAGE CABINETS - 16" & 22" DEEP
LAST TWO DIGITS OF MODEL # INDICATES CABINET WIDTH
WHEN SPECIFYING 22" DEEP ADD SUFFIX 22 i.e. TT1-18-22

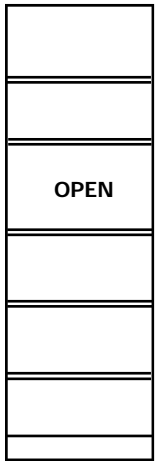

OPEN FRONT

TS9 -18
 TS9 -24

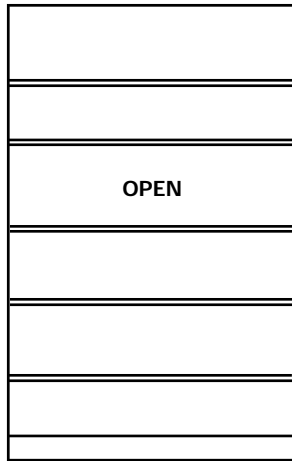

OPEN FRONT

TS10 -30 TS10 -36
 TS10 -42 TS10 -48

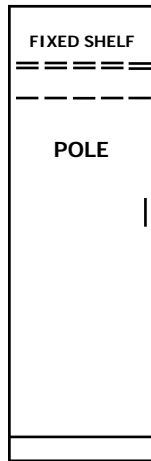

**SINGLE
 WARDROBE**

TS11 -18
 TS11 -24



**SINGLE
 WARDROBE**

TS12 -18
 TS12 -24

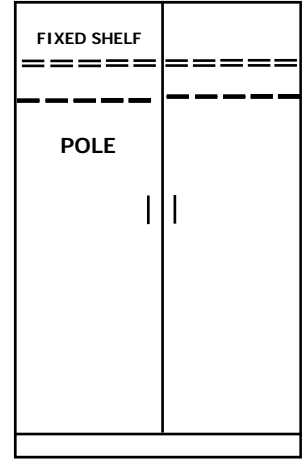

**SINGLE
 WARDROBE**

TS13 -30 TS13 -36
 TS13 -42 TS13 -48

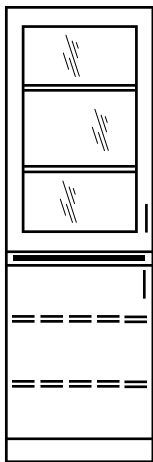

**INSTRUMENT
 STORAGE**

TS14 -18
 TS14 -24

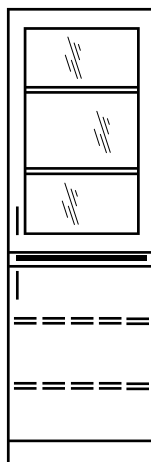

**INSTRUMENT
 STORAGE**

TS15 -18
 TS15 -24

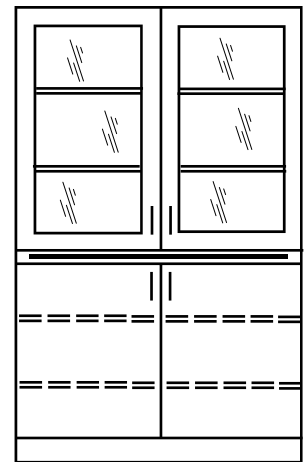

**INSTRUMENT
 STORAGE**

TS16 -30 TS16 -36
 TS16 -42 TS16 -48

NuLAB FURNITURE CORPORATION
11 FEDERAL ROAD Monroe Twp., NJ 08831 (732) 792-0050 FAX 792-0721

NuLAB PHENOLIC CASEWORK

CASEWORK ACCESSORIES & FINISH TRIM

LAST TWO DIGITS OF MODEL NUMBER INDICATES WIDTH

BASE CABINET TOE SPACE FILLERS

STANDING HEIGHT

HTSF-02
HTSF-03
HTSF-04
HTSF-05
HTSF-06



SITTING HEIGHT

LTSF-02
LTSF-03
LTSF-04
LTSF-05
LTSF-06

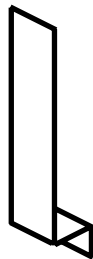

PIPE CHASE FILLER PANELS

STANDING HEIGHT

HPCF-02
HPCF-07
HPCF-08
HPCF-14

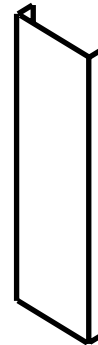

SITTING HEIGHT

LPCF-02
LPCF-07
LPCF-08
LPCF-14

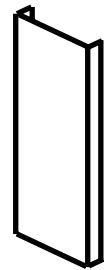

WALL CABINET FILLERS WHEN SPECIFYING 16" DEEP ADD SUFFIX 16 i.e. WCF1-01-16

30" HIGH

WCF1-01
WCF1-02
WCF1-03
WCF1-04
WCF1-05
WCF1-06

36" HIGH

WCF2-01
WCF2-02
WCF2-03
WCF2-04
WCF2-05
WCF2-06

48" HIGH

WCF3-01
WCF3-02
WCF3-03
WCF3-04
WCF3-05
WCF3-06

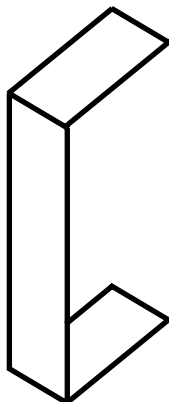

WALL & TALL STORAGE SLOPING TOPS WHEN SPECIFYING 16" OR 22" DEEP ADD SUFFIX 16 i.e. TST-24-16

TST-24 TST-30
TST-36 TST-42
TST-48 TST-60
TST-72 TST-84
TST-96 TST-120

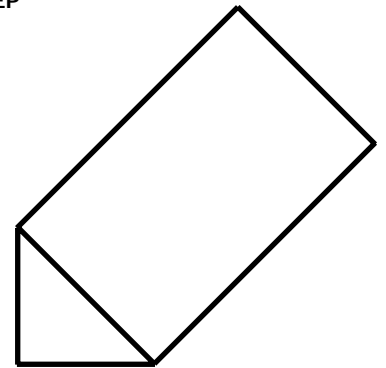

SINK SUPPORTS

SS-18 SS-42
SS-24 SS-48
SS-30 SS-52
SS-36 SS-58

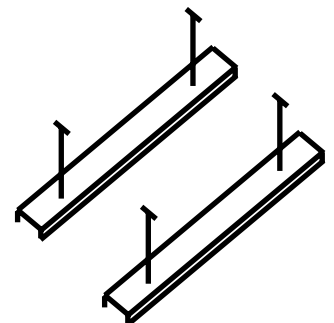

NuLAB FURNITURE CORPORATION

11 FEDERAL ROAD Monroe Twp., NJ 08831 (732) 792-0050 FAX 792-0721

NuLAB PHENOLIC CASEWORK

CASEWORK ACCESSORIES & FINISH TRIM

LAST TWO DIGITS OF MODEL NUMBER INDICATES WIDTH

UNISTRUT PIPE SUPPORTS

STANDING
HEIGHT

HUPS-07
HUPS-08

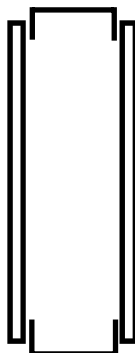

SITTING
HEIGHT

LUPS-07
LUPS-08
LUPS-14

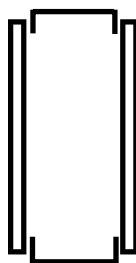

REAGENT SHELF SUPPORTS ALL SUPPORTS TO BE 1" THICK TECH RESIN

12" HIGH 18" HIGH 24" HIGH

RS1-08	RS2-08	RS3-08
RS1-12	RS2-12	RS3-12
RS1-16	RS2-16	RS3-16

30" HIGH 36" HIGH 48" HIGH

RS4-08	RS5-08	RS6-08
RS4-12	RS5-12	RS6-12
RS4-16	RS5-16	RS6-16



PIPE SERVICE CHASE MODEL PSC

WHEN SPECIFYING DETAIL AS FOLLOWS:

PSC - (H) - (W) - (D)
i.e PSC - H60-W12-D12

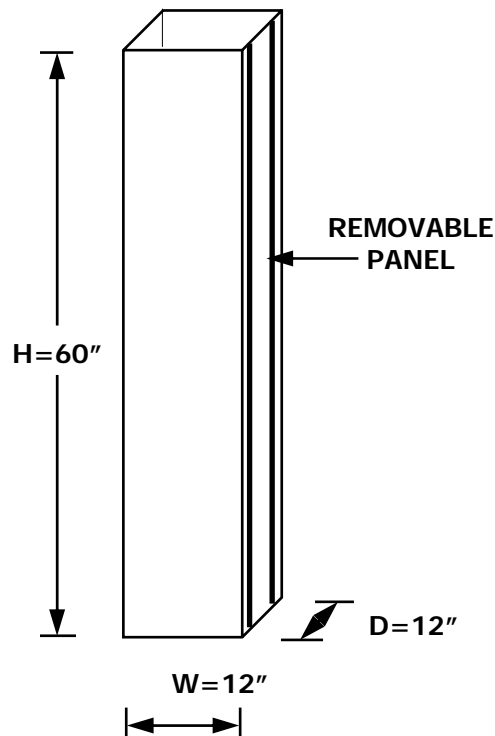

REAGENT SHELF SERVICE TURRETS MODEL RST

WHEN SPECIFYING DETAIL AS
FOLLOWS:

RST - (H) - (W) - (D)

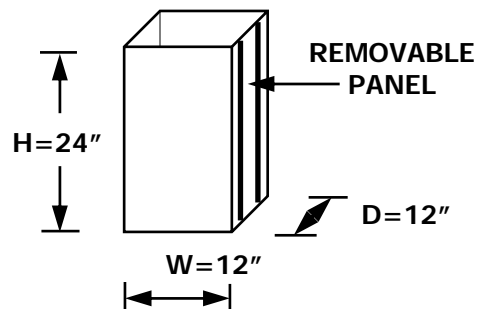

NuLAB FURNITURE CORPORATION

11 FEDERAL ROAD Monroe Twp., NJ 08831 (732) 792-0050 FAX 792-0721

NuLAB PHENOLIC CASEWORK SPECIFICATIONS

PART 1 GENERAL:

1.1 INTENT:

The intent of the following specifications is to provide a general outline of the standard **NuLAB** casework product line. **NuLAB** reserves the right to make any specification and or warranty changes.

1.2 MATERIALS:

NuLAB casework and worksurfaces are guaranteed for a period of 1.5 years. Any defects due to improper or abusive use will be excluded. In addition, routine cleaning and housekeeping practices should be performed for safety and to insure long lasting durability, appearance and service.

PART 2 MATERIALS:

- 2.1 All casework members are to be constructed of phenolic resin in thickness as outlined below.
- 2.2 Drawer suspension system to be 100# load 3/4 extension self closing white epoxy coated steel.
- 2.3 Hinges to be heavy duty 5 knuckle institutional type . Hinges to be powder coated and silver in color
- 2.4 All construction fasteners to be zinc plated.

2.5 MATERIAL THICKNESS OUTLINE:

- * Cabinet sides & bottoms: _____ .5"
- * Door & Drawer fronts: _____ .5"
- * Horizontal rail supports: _____ 1"
- * Drawer bottoms: --- .125"

- * Drawer sides, front & back: _____ .375"
- * Base and wall cabinet backs: _____ .125"
- * Wall cabinet hanging and construction cleat: _____ .5"
- * Casework shelves: _____ .5" thick with .5" stiffeners across front and rear of shelf

2.6 COMPONENT MATERIAL COLORS:

- * Interior of cabinet backs to be white. Remainder of cabinet interior to match exterior. Base and Wall cabinet edges, and support rails to be black.

- * Door and drawer fronts to be selected from our full compliment of colors. All edges to have a polished black finish.

- * All interior and exterior colors to be chemically resistant as per our test result.

NuLAB FURNITURE CORPORATION

MANUFACTURING - DESIGN - SALES - INSTALLATIONS

11 FEDERAL ROAD Monroe Twp., NJ 08831 (732) 792-0050 FAX 792-0721

NuLAB PHENOLIC CASEWORK SPECIFICATIONS

PART 3 CASEWORK CONSTRUCTION:

3.1 Each cabinet manufactured, shall be of mortise and tenon construction resulting in a premium style flush overlay unit. Casework shall be rigid and self supporting, capable of interchangeable use in assembly or as a stand alone cabinet. All vertical and horizontal members shall be keyed in, then pheno seal bonded and mechanically fastened. All exposed edges shall be sanded and polished to a satin smooth finish. Underside and toespace shall be enclosed and vermin proof. Base cabinet backs shall be removable and supplied at cupboard units only. Full base cabinet bottoms to be supplied at cupboard units only.

3.2 Doors shall be squared edged with a slight radius overlay design. Doors shall have a .125" reveal horizontally and vertically as well as a .125" vertical reveal at the ends of the cabinets.

3.3 Drawer body shall be full box construction. Sides, front and back to be Premium Grade Lock Shoulder construction and screwed together on the sides. Material to be 3/8" Thick white phenolic resin. Bottoms of sides, front and back shall be grooved to accept 1/8" Thick white phenolic resin bottom. Drawer fronts are finished similar to doors and shall be screwed on from the back. All drawers shall have self-closing action with a 100 LB. load capacity. Drawer stops to be designed to permit easy removal of drawer, yet prevent inadvertent drawer removal. Drawer shall also have a positive open feature allowing for easy loading of drawer.

3.4 Hinges shall be heavy duty institutional grade. Hinges to be 5 knuckle type. Material of hinges to be powder coated and silver in color. Field adjustment of hinges shall be incorporated in its design.

3.5 Door and drawer pulls to be brushed aluminum. Pulls to be mounted with two screws secured from inside. Additional style pulls available upon request.

3.6 Sides of cabinets to be drilled to accept shelf clips. All shelves to be adjustable on 1.25" increments.

3.7 All base cabinets to have non rusting, adjustable, polystyrene leg levelers attached to the underside of the toespace. Adjusting of levelers shall be from outside the cabinet. The inside bottom of the cabinet shall be free from penetrations, allowing for easy cleaning of the bottom as well as containing any spills and not allowing liquids to fall under the cabinet on to the floor.

NuLAB FURNITURE CORPORATION

MANUFACTURING - DESIGN - SALES - INSTALLATIONS

11 FEDERAL ROAD Monroe Twp., NJ 08831 (732) 792-0050 FAX 792-0721

TEST PROCEDURES

TEST PROCEDURE:

The received panel was placed on a flat surface, cleaned with soap and water and blotted dry. The panel was then conditioned for 48 hours at 73 degrees plus or minus 3 degrees F. and 50 plus or minus 5% relative humidity. The panel was then tested for chemical resistance using (49) different chemical reagents by one of the following methods.

METHOD A - Volatile chemicals were tested by placing a cotton ball saturated with reagent in the mouth of a 1 oz. bottle and inverting the bottle on the surface of the panel.

METHOD B - Non-volatile chemicals were tested by placing five (5) drops of the reagent on the surface of the panel and covering with a 25mm. watch glass.

For both of the above methods, the reagents were left on the panel for a period of 24 hours. The panel was then washed off with water, cleaned with detergent and naphtha, and rinsed with deionized water. The panel was then dried with a towel and evaluated after 24 hours at 73 degrees plus or minus 3 degrees F. and 50 plus or minus 5% relative humidity using the following rating system:

- 0-** No detectable change in working surface material.
- 1** - Slight detectable change in color or gloss, but no change to the function or life of the working surface.
- 2-** Slight surface etching or severe staining.
- 3** - Pitting, cratering, or erosion of working surface material an significant deterioration.

NuLAB FURNITURE CORPORATION

MANUFACTURING - DESIGN - SALES - INSTALLATIONS

11 FEDERAL ROAD Monroe Twp., NJ 08831 (732) 792-0050 FAX 792-0721

TEST RESULTS

<u>TEST #</u>	<u>CHEMICAL REAGENT</u>	<u>TEST METHOD</u>	<u>ATHLON RESULT</u>	<u>TOPLAB RESULT</u>
1	ACETATE, AMYL	A	1	0
2	ACETATE, ETHYL	A	1	0
3	ACETIC, ACID 98%	B	1	0
4	ACETONE	A	1	0
5	ACID DICHROMATE, 5%	B	0	0
6	ALCOHOL, BUTYL	A	0	0
7	ALCOHOL, ETHYL	A	1	0
8	ALCOHOL, METHYL	A	1	0
9	AMMONIUM HYDROXIDE, 28%	B	1	0
10	BENZENE	A	0	0
11	CARBON TETRACHLORIDE	A	0	0
12	CHLOROFORM	A	1	0
13	CHROMIC ACID, 60%	B	2	0
14	CRESOL	A	0	0
15	DICHLOR ACETIC ACID	A	0	0
16	DIMETHYLFORMANIDE	A	2	0
17	DIOXANE	A	0	0
18	ETHYL ETHER	A	0	0
18	FORMALDEHYDE, 37%	A	1	0
20	FORMIC ACID, 90%	B	2	0
21	FURFURAL	A	0	0
22	GASOLINE	A	0	0
23	HYDROCHLORIC ACID, 37%	B	2	0
24	HYDROFLUORIC ACID, 48%	B	2	0
25	HYDROGEN PEROXIDE, 3%	B	2	0
26	IODINE, TINCTURE OF	B	2	0
27	METHYL ETHYL KETONE	A	1	0
28	METHYLENE CHLORIDE	A	1	0
29	MONO CHLOROBENZINE	A	1	0
30	NAPHTALENE	A	0	0
31	NITRIC ACID, 20%	B	3	0
32	NITRIC ACID 30%	B	3	0
33	NITRIC ACID 70%	B	3	3
34	PHENOL, 90%	A	1	0
35	PHOSPHORIC ACID, 85%	B	2	0
36	SILVER NITRATE, SATURATED	B	1	0
37	SODIUM HYDROXIDE, 10%	B	1	0
38	SODIUM HYDROXIDE, 20%	B	1	0
39	SODIUM HYDROXIDE, 40%	B	2	0
40	SODIUM HYDROXIDE, FLAKE	B	2	0
41	SODIUM SULFIDE, SATURATED	B	0	0
42	SULFURIC ACID, 33%	B	2	0
43	SULFURIC ACID, 77%	B	2	0
44	SULFURIC ACID, 96%	B	2	2
45	SULFURIC ACID 77% & NITRIC ACID 70% EQUAL PARTS	B	2	3
46	TOLUENE	A	0	0
47	TRICHLOROETHYLENE	A	1	0
48	XYLENE	A	0	0
49	ZINC CHLORIDE, SATURATED	B	0	0

NuLAB FURNITURE CORPORATION

MANUFACTURING - DESIGN - SALES - INSTALLATIONS

11 FEDERAL ROAD Monroe Twp., NJ 08831 (732) 792-0050 FAX 792-0721